

4

3

2

1

REVISIONS				
ZONE	LTR	DESCRIPTION	DATE	APPROVED

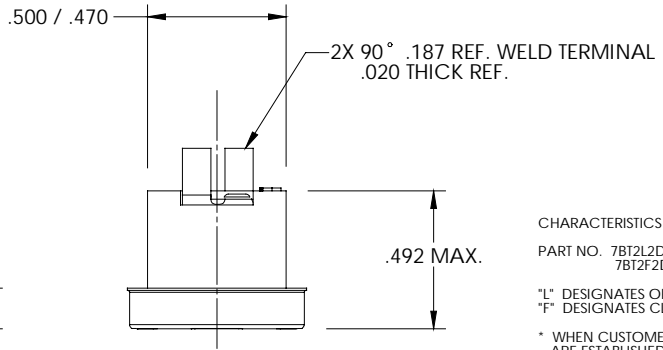
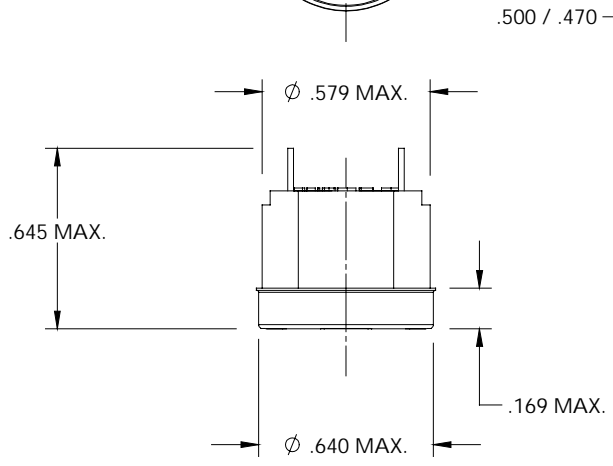
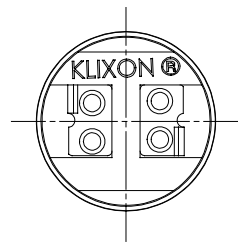

CHARACTERISTICS
 PART NO. 7BT2L2D-**-**
 7BT2F2D-**-**
 * "L" DESIGNATES OPEN ON TEMPERATURE RISE
 * "F" DESIGNATES CLOSE ON TEMPERATURE RISE
 * WHEN CUSTOMER'S TEMPERATURE CHARACTERISTICS ARE ESTABLISHED, A DASH NO. WILL BE ASSIGNED, THEREBY COMPLETING THE PART NO.
 ** WHEN WIRE LEADS ARE REQUESTED, A SECOND DASH NO. WILL BE ASSIGNED, THEREBY COMPLETING THE PART NO.

UNLESS OTHERWISE SPECIFIED DIMENSIONS ARE IN INCHES				DRAWN: S. MARQUIS		DATE: 3/25/02		TEXAS INSTRUMENTS ATILEBORO MA 02705					
TOLERANCES ON FRACTIONS AND ANGLES				APPROVED:		APPROVED:		TITLE: THERMOSTAT SWITCH ENVELOPE DRAWING					
MATERIAL:				APPROVED:		APPROVED:		SIZE: B		CODE IDENT NO.: 82647			
NEITHER THIS PRINT NOR THE INFORMATION CONTAINED THEREON IS TO BE USED AGAINST THE INTEREST OF TEXAS INSTRUMENTS, INC. OR AGAINST THE INTERESTS OF ANY OF ITS AFFILIATED COMPANIES OR WHOLLY OWNED SUBSIDIARIES.				FOR REFERENCE ONLY CONSULT TEXAS INSTRUMENTS CUSTOMER SERVICE FOR LATEST REVISION BEFORE USE				SIGNATURES ON FILE. REFER TO ELECTRONIC CHANGE NOTICE.		SCALE:		SHEET:	

4

3

2

1

NEITHER THIS PRINT NOR THE INFORMATION CONTAINED THEREON IS TO BE USED AGAINST THE INTEREST OF TEXAS INSTRUMENTS, INC. OR AGAINST THE INTERESTS OF ANY OF ITS AFFILIATED COMPANIES OR WHOLLY OWNED SUBSIDIARIES.

FOR REFERENCE ONLY CONSULT TEXAS INSTRUMENTS CUSTOMER SERVICE FOR LATEST REVISION BEFORE USE

TITLE: THERMOSTAT SWITCH ENVELOPE DRAWING
 SIZE: B
 CODE IDENT NO.: 82647
 SHEET: 7BT2-2D STYLE